



MOST ENVIRONMENTALLY RESPONSIBLE -

Available in our LP™ Premium or L10™ Optimum range. No heavy metals or carcinogens!

LONG LIFE LED - Energy efficient, Long Life.

Lifetime lamp warranty.

LOW POWER CONSUMPTION - Ultra-low 1 Watt

power consumption.

TESTING OPTIONS - Clevertest™, DALI compatible

and Zoneworks® computerised testing options available in our Premium range.

The Premium Lifelight™ delivers low cost maintenance and a high performance emergency lighting solution.

Premium Lifelight™ delivers superior light output achieving higher levels of compliance. New, longer lasting Lithium Iron Phosphate battery technology makes the Premium Lifelight™ the most environmentally responsible emergency light on the market. For reliable performance, the Premium Lifelight™ is available in long lasting, high brightness, energy efficient LED.

Retrofitting is easy with an adapter plate to suit older applications in the one box. Tamper resistant with no dome required, the Premium Lifelight™ is suitable for most emergency lighting applications.

SAVE TIME AND MONEY ON INSTALLATION WITH LIFELIGHT

With an impressive D40 spacing classification the LP™ LIFELIGHT™ delivers higher levels of compliance.

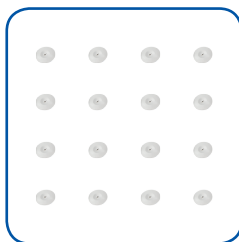

STANDARD ECONOMY

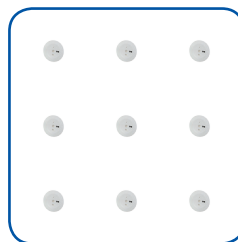

STANDARD PREMIUM

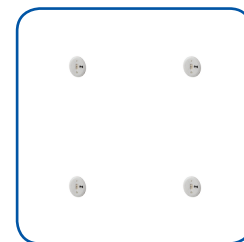

LIFELIGHT NOW DELIVERS

Based on area of 3350m² @ 2.7m ceiling height, required quantity to meet AS/NZS2293.

SEGMENT - LAMP TYPE	PART NUMBER & TESTING OPTIONS				
	Single-point	Clevertest™	DATA	DALI EM	Zoneworks®
LP - LED	CLIFE	CLIFE-CT	CLIFE-DATA	CLIFE-DALI	CLIFE-ZW
LP - LED	CLIFE-SMS	CLIFE-SMS-CT	CLIFE-SMS-DATA	CLIFE-SMS-DALI	CLIFE-SMS-ZW
L10 - LED	LLIFE	LLIFE-CT	LLIFE-DATA	LLIFE-DALI	LLIFE-ZW
L10 - LED	LLIFE-SMS	LLIFE-SMS-CT	LLIFE-SMS-DATA	LLIFE-SMS-DALI	LLIFE-SMS-ZW

LP PREMIUM LED

Recessed or surface mount emergency light, long life LED, environmentally responsible, low maintenance, long life Lithium Iron Phosphate battery, 2 year back to base warranty. (Lifetime lamp warranty)

L10 OPTIMUM LED

Recessed or surface mount emergency light, long life LED, state of the art environmentally responsible Lithium Iron Phosphate battery with no heavy metals or carcinogens, 4 year back to base warranty, double the service life of the Nickel Cadmium battery, one of the most energy efficient emergency lights on the market. (Lifetime lamp warranty)

TESTING OPTIONS

clevertest	Exit and Emergency luminaires automatically test every six months.
DALI EM	Smooth integration and networking with DALI Lighting Control Systems.
ZONEWORKS	A real-time, automatic monitoring and testing facility for emergency luminaires.

AVAILABLE FITTING OPTIONS

Entire range available in white and black in both recessed round and surface mount.

Head: 95mm diameter, Hole cut-out: 85mm diameter, Adaptor Plate: 145mm diameter, Head height: 40mm (recessed)

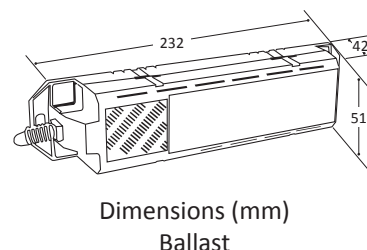
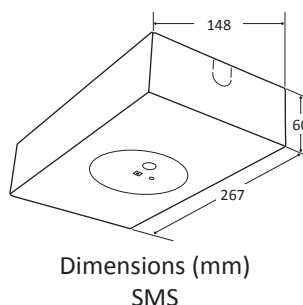
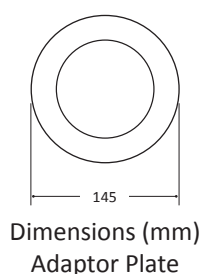
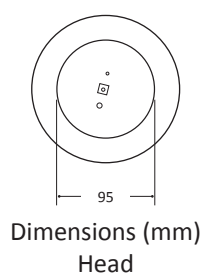

SPECIFICATIONS

	Warranty	Power Consumption	C0	C90
CLIFE	2 YEARS	1W	D40	D40
LLIFE	4 YEARS	1.3W	D32	D32

SPACING TABLE & MOUNTING HEIGHTS

Classification	2.1m	2.4m	2.7m	3m	3.3m	3.6m	4m	4.5m	5m	6m	7m	10m
D32	15.4	16.1	16.7	17.2	17.6	18.0	18.5	19.1	19.5	20.2	20.6	20.3
D40	16.7	17.4	18.0	18.6	19.1	19.6	20.1	20.8	21.3	22.1	22.7	23.1

Based on minimum light level of 0.2 lux

Version: October 2014-5

Please check our website for your closest Clevertronics office and local representative. Due to changes in industry standards and Clevertronics policy of product improvement, specification details are subject to change without notice.